

1-1-2015

Combinational Watermarking for Medical Images

Thrilok Chakravarthy Chinna Narayana Swamy
University of South Florida, thrilok@mail.usf.edu

Follow this and additional works at: <http://scholarcommons.usf.edu/etd>

 Part of the [Electrical and Computer Engineering Commons](#)

Scholar Commons Citation

Chakravarthy Chinna Narayana Swamy, Thrilok, "Combinational Watermarking for Medical Images" (2015). *Graduate Theses and Dissertations*.
<http://scholarcommons.usf.edu/etd/5833>

This Thesis is brought to you for free and open access by the Graduate School at Scholar Commons. It has been accepted for inclusion in Graduate Theses and Dissertations by an authorized administrator of Scholar Commons. For more information, please contact scholarcommons@usf.edu.

Combinational Watermarking for Medical Images

by

Thrilok Chakravarthy Chinna Narayana Swamy

A thesis submitted in partial fulfillment
of the requirements for the degree of
Master of Science in Electrical Engineering
Department of Electrical Engineering
College of Engineering
University of South Florida

Major Professor: Ravi Sankar, Ph.D.
Wilfrido Moreno, Ph.D.
Nasir Ghani, Ph.D.

Date of Approval:
March 16, 2015

Keywords: Wavelet Transform, Spatial Domain, Structural Similarity, Normalized Correlation,
Shared Key

Copyright © 2015, Thrilok Chakravarthy

DEDICATION

I would like to dedicate my thesis to my beloved mother, father and sister.

ACKNOWLEDGMENTS

I take this opportunity to thank my committee members, who have given their valuable time and suggestions. A special thanks to my major professor and advisor, Dr. Ravi Sankar for all the support and patience throughout this process.

TABLE OF CONTENTS

LIST OF TABLES	ii
LIST OF FIGURES	iii
ABSTRACT	v
CHAPTER 1: INTRODUCTION	1
1.1 Background	1
1.1.1 History of Watermarking	2
1.1.2 Medical Image Watermarking and Applications	3
1.2 Problem Statement and Motivation	4
1.3 Thesis Goals and Outline	4
CHAPTER 2: DESCRIPTION OF PAST RESEARCH AND PROPOSED SYSTEM	6
2.1 Existing Systems	6
2.2 Proposed System	9
CHAPTER 3: IMAGE PROCESSING BASICS	11
3.1 Discrete Wavelet Transform (DWT)	11
3.2 Peak Signal to Noise Ratio (PSNR)	14
3.3 Structural Similarity (SSIM)	15
3.4 Normalized Correlation (NC)	16
CHAPTER 4: WATERMARKING	17
CHAPTER 5: EXTRACTION	32
5.1 Extraction Process	32
5.1 Comparison	36
CHAPTER 6: CONCLUSION	38
6.1 Summary	38
6.2 Future Work	39
REFERENCES	40
APPENDICES	42
Appendix A Copyright Permissions	43

LIST OF TABLES

Table 1 α , PSNR and Watermarked Images	30
Table 2 Recovered Data Measurements	34
Table 3 Recovered Data Measurements in Presence of Noise	36
Table 4 Comparison of Results with Existing System.....	37

LIST OF FIGURES

Figure 1 Basic Watermarking Process.....	2
Figure 2 DWT-JND based Watermarking.....	7
Figure 3 Combinational Watermarking using DCT.....	7
Figure 4 Host Image.....	8
Figure 5 Bit-planes of the Test Image.....	9
Figure 6 Proposed Watermarking Block Diagram.....	10
Figure 7 Matrix Representation of an Image.....	11
Figure 8 2D Wavelet Coefficients.....	12
Figure 9 Level - 2 DWT Coefficients.....	13
Figure 10 Level - 3 DWT Coefficients.....	13
Figure 11 DWT Synthesis.....	14
Figure 12 SSIM Images.....	16
Figure 13 Frequency Domain Watermarking Process.....	17
Figure 14 Original Gray Scaled Shared Image.....	18
Figure 15 Original Gray Scaled Medical Image.....	19
Figure 16 Level - 1 Shared Image DWT Coefficients.....	20
Figure 17 Level - 2 Shared Image DWT Coefficients.....	21
Figure 18 Level - 3 Shared Image DWT Coefficients.....	21
Figure 19 Level - 1 LL Coefficients Shared Image of Size 1024 x 1024.....	22

Figure 20 Level - 2 LL Coefficients Shared Image of Size 512 x 512.....	22
Figure 21 Level - 3 LL Coefficients Shared Image 256 x 256	23
Figure 22 Level - 1 Medical Image DWT Coefficients.....	23
Figure 23 Level - 2 Medical Image DWT Coefficients.....	24
Figure 24 Level - 1 Medical Image DWT Coefficients.....	24
Figure 25 Level - 1 Medical LL Coefficients Image of Size 1024 x 1024.....	25
Figure 26 Level - 2 Medical LL Coefficients Image of Size 512 x 512.....	25
Figure 27 Level - 3 Medical LL Coefficients Image of Size 256 x 256.....	26
Figure 28 Medical Image for RONI.....	26
Figure 29 RONI of Medical Image.....	27
Figure 30 Patient Data Image	27
Figure 31 Scrambled Patient Data	28
Figure 32 Watermarked Shared Image of Size 2048 x 2048.....	31
Figure 33 Extraction	32
Figure 34 Recovered Medical Image.....	33
Figure 35 Recovered Scrambled Patient Data	33
Figure 36 Descrambled Patient Data Image	33
Figure 37 Noise Descrambled Patient Data Image.....	35
Figure 38 Noise Recovered Medical Image.....	35

ABSTRACT

Digitization of medical data has become a very important part of the modern healthcare system. Data can be transmitted easily at any time to anywhere in the world using Internet to get the best diagnosis possible for a patient. This digitized medical data must be protected at all times to preserve the doctor-patient confidentiality. Watermarking can be used as an effective tool to achieve this.

In this research project, image watermarking is performed both in the spatial domain and the frequency domain to embed a shared image with medical image data and the patient data which would include the patient identification number.

For the proposed system, Structural Similarity (SSIM) is used as an index to measure the quality of the watermarking process instead of Peak Signal to Noise Ratio (PSNR) since SSIM takes into account the visual perception of the images compared to PSNR which uses the intensity levels to measure the quality of the watermarking process. The system response under ideal conditions as well as under the influence of noise were measured and the results were analyzed.

CHAPTER 1: INTRODUCTION

1.1 Background

In this age of Internet, we are connected to each other by the internet. Data sharing has become an integral part of our lives for example people are sharing pictures, videos, documents, maps between each other to help in better communication of information. The scientific community also uses the data sharing possibilities in communicating ideas or work which includes hospitals exchanging private patient information between doctors or hospital workers. Private patient data includes medical data such as medical images. This has given rise for the need to protect the patient data, medical images so that there is no tampering by unauthorized persons or the private data becoming public. Watermarking has become one of the biggest tools used to protect the data. In this thesis we will be discussing about medical image watermarking and propose a system to perform the same.

Let us first discuss about watermarking generally and its applications. Watermarking is the process embedding a hidden digital signal or information called a watermark inside a host signal. The host signal can be an image, audio or video signal. The watermark is added such that the process of adding this does not corrupt or degrade the original host signal and the composite signal is robust. Watermarking includes both physical and electronic data, an example for physical watermarking are products watermarked using invisible dyes or inks [1].

The watermarking process can be represented by a block diagram shown in Figure 1. The embedding process takes two inputs, host signal and the watermark. These can be audio, image, video or any other type of information. The embedding process adds the watermark data onto the host signal using a specified algorithm. The output is transmitted or recorded. The second block called attack represents any changes made on the watermarked host signal. The attacks may include addition of transmission noise, cropping, etc. The third block represents the detecting process. The detection process runs an algorithm to determine or separate the host signal and the watermark.

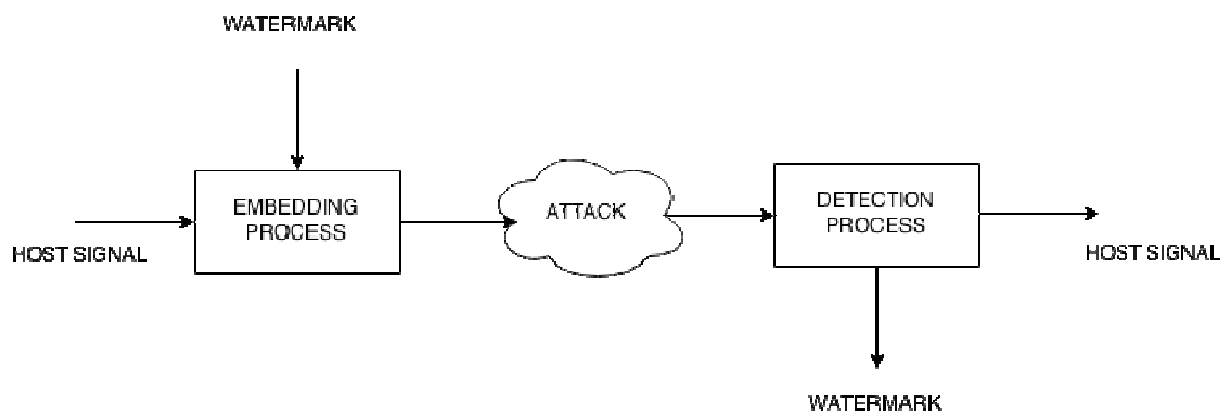

Figure 1 Basic Watermarking Process

1.1.1 History of Watermarking

Watermarking started with paper manufacturers as back as in 1200's. They were used to identify the paper manufacturer and the paper size [1]. Later in the 18th century watermarking was used to stop counterfeiting of currency and other documents. Szepanski [2] discussed the first digital watermarking scheme to detect patterns that could be embedded on documents or currency for anti-counterfeiting. Next, Holt *et al.* [3] described a process to embed data in to an audio signal. As the years progressed, the watermarking industry took off with the formation of

the Copy Protection Technical Working Group (CPTWG) [4] and the Secure Digital Music Initiative (SDMI) [5] which came up with new watermarking algorithms for videos, music, and images.

1.1.2 Medical Image Watermarking and Applications

Medical data is exchanged easily in a modern integrated systems such as Hospital Information System (HIS) and Picture Archiving and Communication System (PACS) [6, 7, 8, 9, and 10]. Wong et al. first published a paper in 1995 [11] with their research on authenticity and integrity of medical image. Some of the publications discuss methods to modify the medical image with required diagnosis information [12], the embedded data may be patient information such as name, age, sex [13].

The embedding algorithm for medical image watermarking and watermarking in general can be classified as spatial, spectral or frequency and hybrid or combinational watermarking. In spatial domain, the watermark is embedded directly by changing the pixel intensity values of the host image. But spatial domain watermarking are weak against noise or lossy compression attacks. In the frequency domain, the watermark is embedded to the transformed version of the host image. Finally in the combinational domain, the watermarks are embedded in both the spatial domain and frequency domain.

Image watermarking can also been classified according to human perception as either visible watermarking or invisible watermarking. Visible watermarks include logos placed on images. Invisible watermarks are used for authentication, copyright protection.

Medical image watermarking has be used for many applications [14] like authenticity, owner verification, indexing, access control, origin identification. The electronic patient record

(EPR) and the medical image can be stored together by embedding the medical image with the EPR thus saving storage space. This was introduced by A. Giakomaki *et al.* [15]. G. Coatrieux *et al.* [16] and E.T. Lin *et al.* [17] explains fragile watermarking techniques which can be used to identify if an image has been modified or not.

1.2 Problem Statement and Motivation

Medical image watermarking is not an easy task since the image has to be protected at all costs. Some of the methods used in medical watermarking involve the watermarking process performed either in just spatial domain or in just frequency domain. The algorithms involving both the domains are less and the results have also been not great for the combinational system.

The motivation of this thesis research is to build a robust watermarking scheme for medical images. To protect the medical data and the patient data, the watermarking is done in both the spatial and frequency domain. This increases the amount of data stored and also helps in hiding the medical image and the patient data in an efficient way. One of main the advantages of the system is that, the secure data (i.e., medical and patient data) is watermarked onto a random image which would mislead a third person into thinking that the image has nothing embedded on it.

1.3 Thesis Goals and Outline

The main goal of this thesis is to build an image watermarking process such that the security of the medical image and patient data is protected at all times. The other goals of the thesis are:

- Study the effect of combinational watermarking on the images and determine whether it changes the human perception or not.

- Study the image processing terms used and process how they vary the results of the proposed system.
- Compare the results of the algorithm with an existing system [18] under ideal conditions as well as in the presence of noise.

The rest of the thesis is organized as follows. In the next chapter, some of the existing systems used as the benchmark are discussed in detail. The chapter also introduces the overview of the proposed system with a discussion of the basic setup of the proposed system. In Chapter 3, the image processing terms used throughout the thesis are described in detail. In Chapter 4, the proposed watermarking process is described with results for the watermarking process. In Chapter 5 the extraction process is discussed and the chapter also includes discussion of results obtained and how the results compare to the results of an existing system. Finally in Chapter 6, the conclusions of the thesis and recommendations for future research are provided.

CHAPTER 2: DESCRIPTION OF PAST RESEARCH AND PROPOSED SYSTEM

2.1 Existing Systems

In this section some of the existing image watermarking systems are discussed. Shin *et al.* [18] implemented a watermarking method in frequency domain. The system block diagram is illustrated in Figure 2. In this watermarking process, the watermark which is a random sequence of numbers is embedded on to the original image in the frequency domain.

The discrete wavelet transform (DWT) of the original image gives the coefficients of the image. The coefficients are varied such that the resultant image does not have any visible differences compared to the original image. This is performed by calculating a factor called just noticeable factor (JND). JND calculation depends on the intensity levels of the image. In simple terms it can be described as the smallest change in the intensity levels of an image which can be noticed by the human eye. The main drawback of using JND as a parameter to watermark is that calculation of JND does not take into effect the sensitivity of the human eye to notice textural change in an image, not just the intensity levels. The watermarked image is obtained after taking the inverse transform (IDWT) of the resultant image.

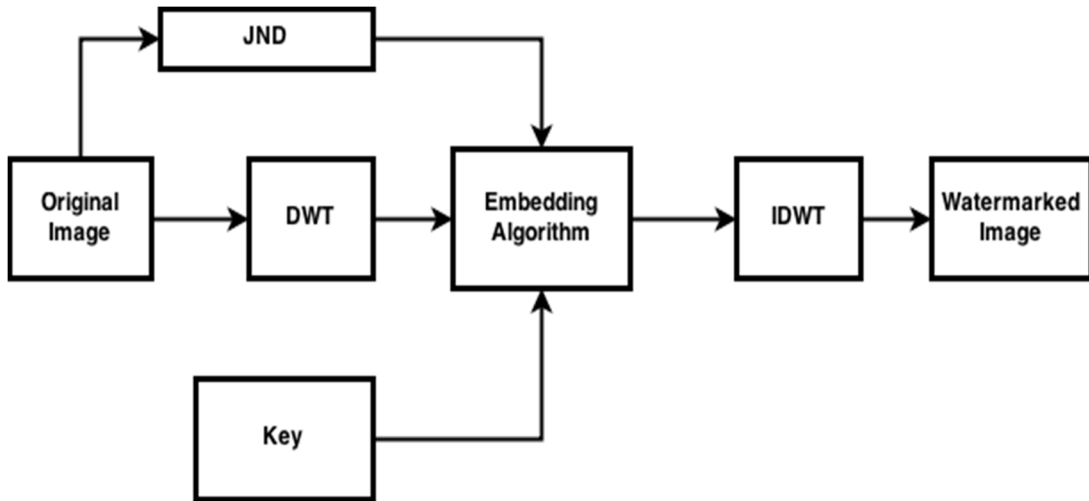

Figure 2 DWT-JND based Watermarking

In the next system example by L. Zhang et al. [19], the watermarking is done in both the spatial domain as well as the frequency domain. The watermarking process is shown in Figure 3.

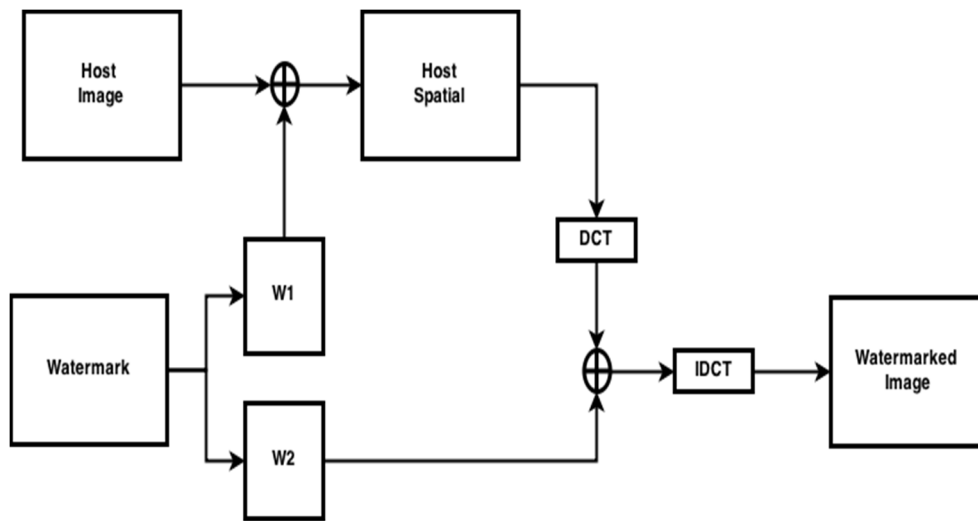

Figure 3 Combinational Watermarking using DCT

The watermark to be added is divided into two parts (W1 and W2). W1 is added to the host image by bit plane mapping. Bit plane mapping is the process in which each pixel intensity value is represented in binary. The most significant bits (MSBs) carry almost all the required

information of the pixel, in bit plane mapping the LSBs of the host images are replaced by the MSBs of W1.

Bit planes of a host image (Figure 4) are shown in Figure 5.



Figure 4 Host Image ¹

The images in Figure 5 are plots of the data carried by each bit plane. The host image pixels are represented by 8 bits. The pixel intensity values in binary format represented by 8-bits each gives the image plots as illustrated in Figure 5. We can observe from the figure that bit-plane 1, bit-plane 2 and bit-plane 3 contain negligible information of the image data whereas bit-plane 4 contains a very small amount of information about the image data. Finally the MSB bit-planes 5, 6, 7 and 8 contain most of the information in the image data. If we replace LSB bits of the host image with the most significant bits (MSBs) of the watermark image (W1), this will not affect the image perception, unless the MSBs replacing in the LSBs contain lot of contrast variations.

¹ Image available in Public Domain

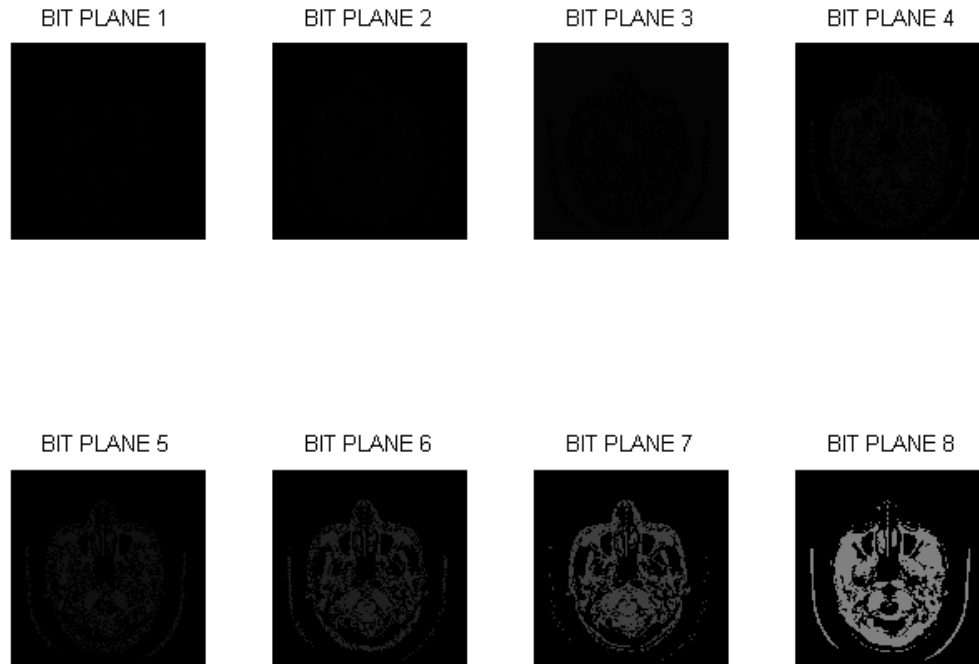

Figure 5 Bit-planes of the Test Image

In the frequency domain, the spatially watermarked image is transformed in the frequency domain by finding its discrete cosine transform (DCT). The DCT coefficients are added with the W2 values and inverse transform (IDCT) of this gives the combinational domain watermarked image.

2.2 Proposed System

In the proposed system, the watermarking process is performed in both the spatial domain and the frequency domain. The watermarking system is illustrated as a block diagram in Figure 6.

To increase the security of the system, the required data is embedded on to a random image called the shared image. The shared image is common for both the watermarking and extraction processes.

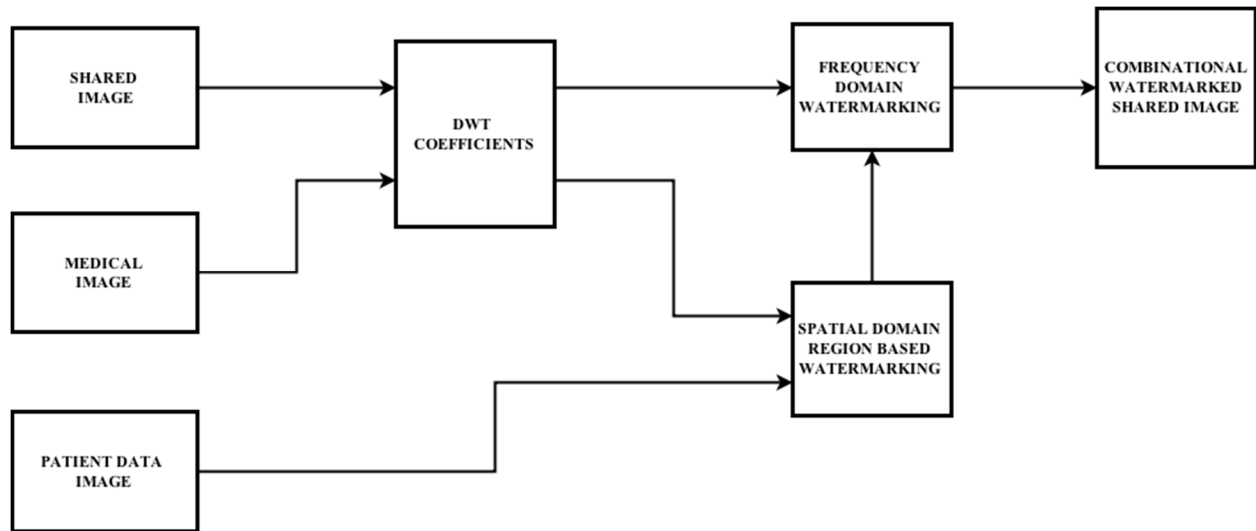

Figure 6 Proposed Watermarking Block Diagram

The DWT coefficients of shared image and the medical image is calculated, the patient data is embedded onto the DWT coefficients of the medical image: this forms the spatial domain watermarking. Next the resultant image coefficients are embedded to the shared image, since this change is done to the DWT coefficients: this forms the frequency domain watermarking step.

CHAPTER 3: IMAGE PROCESSING BASICS

3.1 Discrete Wavelet Transform (DWT)

An image is represented by a two dimensional matrix which consists of $M \times N$ elements, each element is called a pixel as shown in Figure 7.

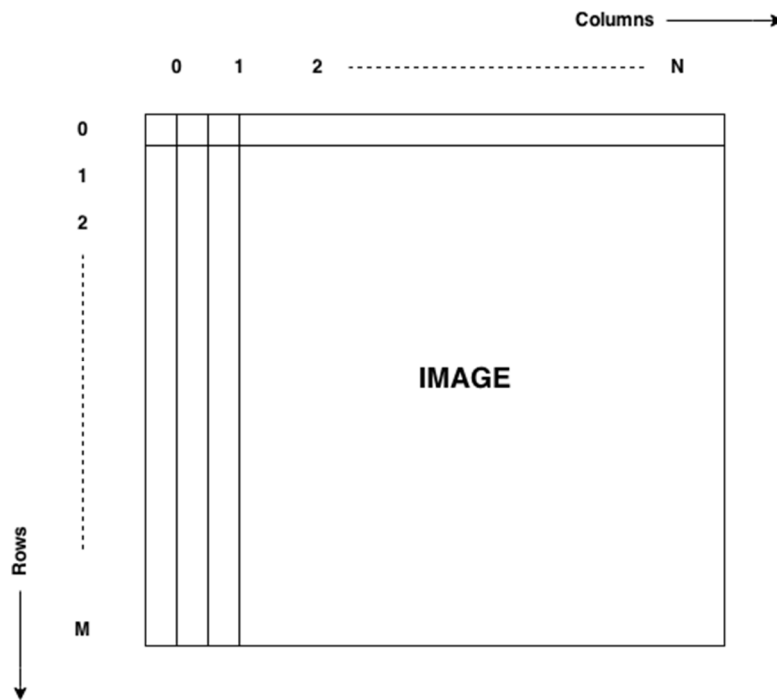

Figure 7 Matrix Representation of an Image

Two dimensional wavelet transform [20] of an image gives a set of four wavelet coefficients corresponding to the image as shown in Figure 8.

The image coefficients are explained below:

- LL: Consists of all coefficients, which were filtered by the low pass filter along the rows and then filtered along the corresponding columns using the same low pass filter. It denotes the approximated version of the original image at half resolution.
- HL/LH: Consists of all the coefficients which were filtered along the rows and columns with the low pass filter and high pass filter. The LH coefficients represent the vertical edges and the HL coefficients represent the horizontal edges.
- HH: Consists of all the coefficients which were filtered along the rows and columns with the high pass filter. The HH coefficients represent the diagonal edges.

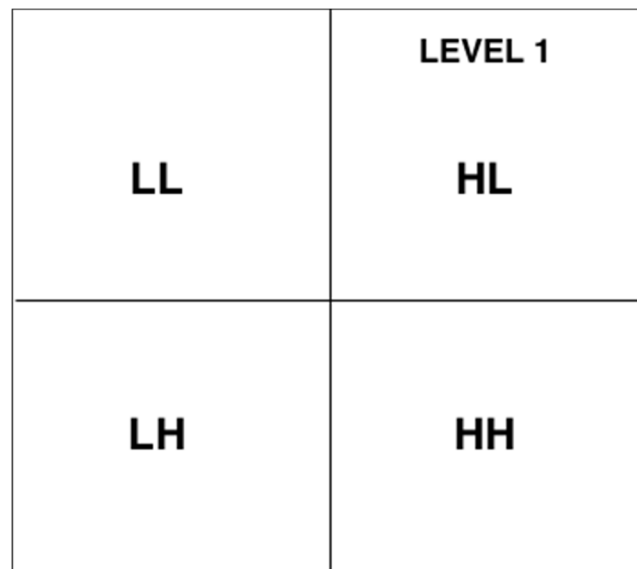

Figure 8 2D Wavelet Coefficients

In the second level wavelet transform, the LL block is used to obtain the second level transform coefficients LL_2 , HL_2 , LH_2 , HH_2 . Continuing the same process, the third level transform coefficients LL_3 , HL_3 , LH_3 , HH_3 can be obtained, as shown in Figures 9 and 10 below.

LL2	HL2	LEVEL 2 HL
LH2	HH2	
LH		HH

Figure 9 Level - 2 DWT Coefficients

LL3	HL3	HL2	LEVEL 3 HL
LH3	HH3		
LH2		HH2	LH
LH		HH	

Figure 10 Level - 3 DWT Coefficients

The three level DWT synthesis can be illustrated by Figure 11. The 2D-DWT (two dimensional DWT) of an image yields LL, HL, LH and HH coefficients, these are the first level DWT coefficients. To calculate the second level DWT coefficients, the LL coefficients of the first level is used as the input. The second level DWT coefficients obtained are LL2, HL2, LH2 and HH2. Finally the LL2 is used to calculate the third level coefficients LL3, HL3, LH3 and HH3.

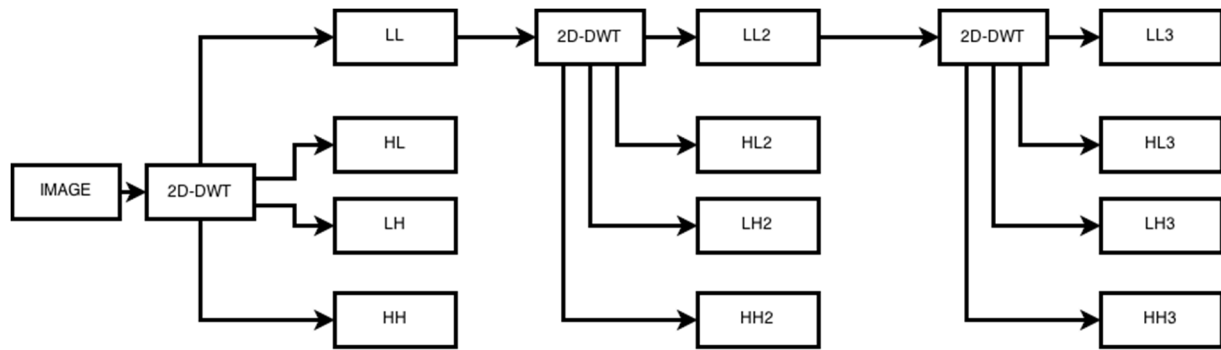

Figure 11 DWT Synthesis

3.2 Peak Signal to Noise Ratio (PSNR)

The quality of an image is calculated using PSNR. The PSNR of an image is calculated using Equation (1). The PSNR is in decibel scale, images having PSNR values above 40 dB are indistinguishable by the human eye from the original image

$$PSNR (dB) = 10 \times \log_{10} \left[\frac{MAX^2}{MSE} \right] \quad (1)$$

where MSE is the Mean Square Error between the original image and the watermarked image, MAX is the maximum intensity value of the image. The intensity values can be integers or double values.

MSE of an image is calculated by Equation (2).

$$MSE = \frac{1}{M \times N} \sum_{i=1}^M \sum_{j=1}^N [I(i,j) - I^*(i,j)]^2 \quad (2)$$

where M, N denote the size of the image, I is the original image, and I* is the watermarked image

3.3 Structural Similarity (SSIM)

Structural similarity (SSIM) defined as Equation (3) by Wang *et al.* [22] is a function which describes similarity between images to human visual system (HVS). SSIM has values between '0' and '1'. Images that are similar have SSIM values closer to '1'.

$$SSIM = \frac{(2\mu_x\mu_y + c_1)(2\sigma_{xy} + c_2)}{(\mu_x^2 + \mu_y^2 + c_1)(\sigma_x^2 + \sigma_y^2 + c_2)} \quad (3)$$

where μ , σ^2 , σ_{xy} are mean, variance, and covariance of the images and c_1 , c_2 are the stabilizing constants .

Structural similarity is a better comparison measure than PSNR of an image because it tells us how a human eye perceives changes in an image which includes textural changes. The structural similarity is calculated by comparing the luminance and contrast levels of two image pixels with respect to themselves as well as the background.

SSIM can be illustrated by Figure 12, it explains the requirement for using SSIM as an index to check quality of an image compared to PSNR. All the images illustrated in Figure 12 have a size of 515 x 512, the images also have an MSE = 210, PSNR = 24.9 dB. But the SSIM gives you different result when each of the images illustrated are compared with the original image (Figure 12 (a)) [24]. The processed images (the image process applied to the original is as mentioned) in Figure 12 are as listed below.

- Contrast-stretched image, SSIM = 0.9168 (Figure 12 (b)).
- Mean-shifted image, SSIM = 0.99 (Figure 12 (c)).
- JPEG compressed image, SSIM = 0.6949 (Figure 12 (d)).
- Blurred image, SSIM = 0.7052 (Figure 12 (e)).

- Noise contaminated image, SSIM = 0.7748 (Figure 12 (f)).

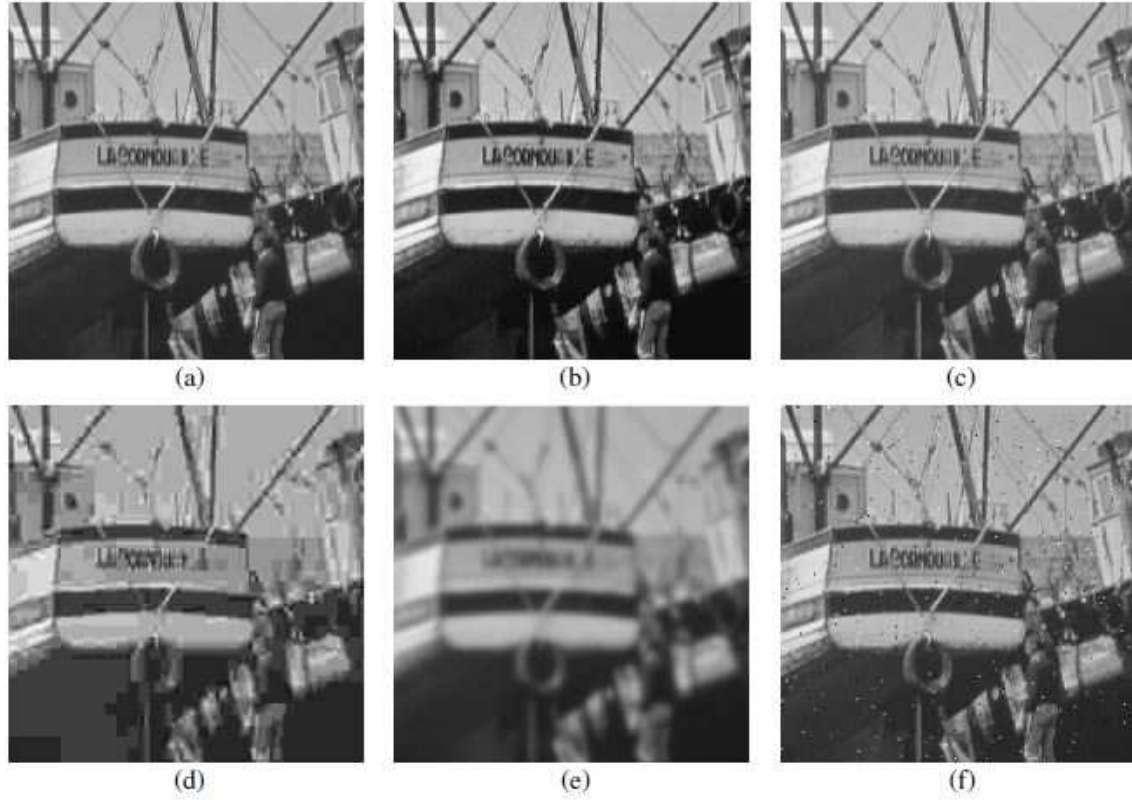

Figure 12 SSIM Images ²

3.4 Normalized Correlation (NC)

Normalized correlation (NC) defined by Equation (4) by J.P. Lewis [23] gives the correlation coefficients in the range -1 to 1. This can be used to check for similarity of two images, NC of similar images is closer to 1.

$$NC = \frac{\sum_{i=1}^M \sum_{j=1}^N H_1(i, j) H_2(i, j)}{\sum_{i=1}^M \sum_{j=1}^N [H_1(i, j)]^2} \quad (4)$$

where M, N denote the size of the image, H₁ and H₂ denote the original image and similar image, respectively.

² Reproduced from [24], Permissions attached in Appendix A

CHAPTER 4: WATERMARKING

The watermarking process is illustrated by the block diagram shown in Figure 13.

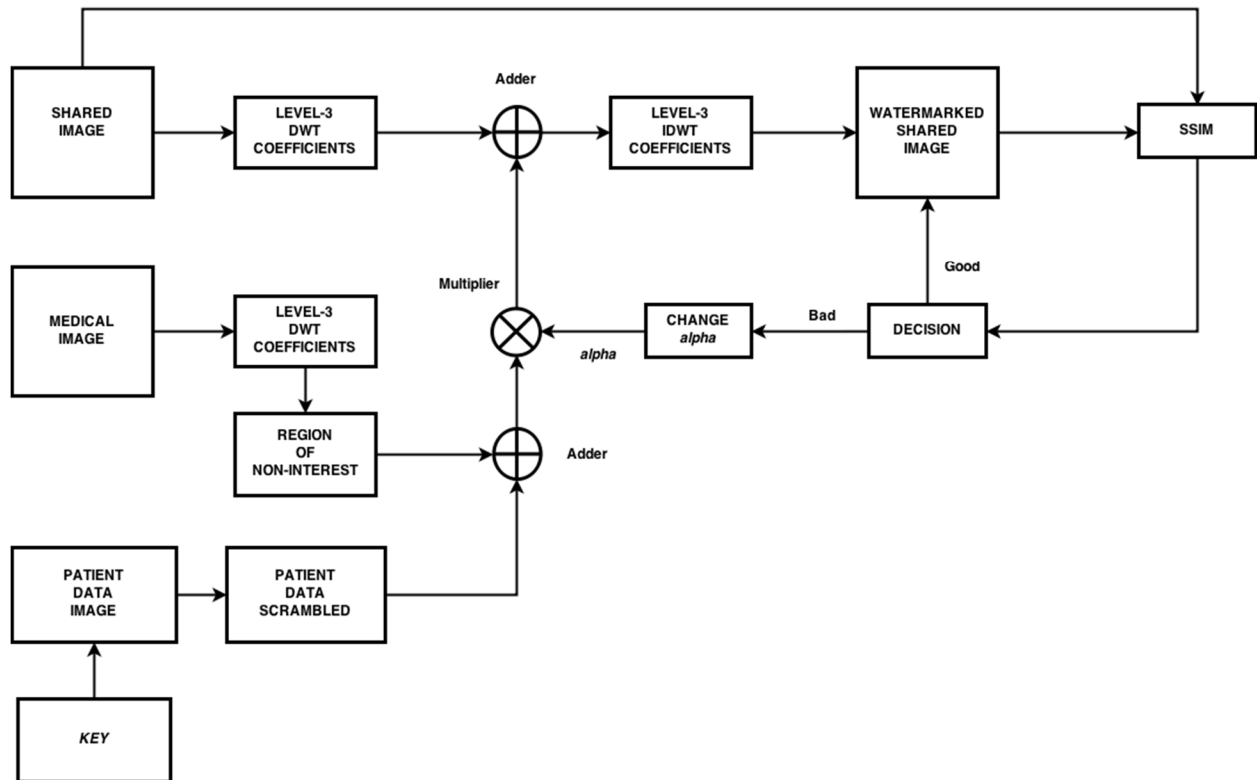

Figure 13 Frequency Domain Watermarking Process

The watermarking process starts with three images,

- Shared image: random image common at the watermarking side and the detection side.
- Medical image: the actual medical image of the patient to be watermarked
- Patient data image: the image which carries the patient data, patient data used in the example consists of the patient identity number and the date of birth.

First, the original shared image and the medical image are shown in Figures 14 and 15, respectively. These images are converted to grayscale and to same size (2048 x 2048), if they are not so. The image size is not fixed and can be changed. If the shared image size is changed, the medical image should also be resized to the same size.

TOP LEVEL IMAGE



Figure 14 Original Gray Scaled Shared Image ³

³ Image available in Public Domain



Figure 15 Original Gray Scaled Medical Image

The three level 2 - D DWT [20] components of the shared image and the medical image data is calculated using the Haar wavelet to obtain [LL, HL, LH, HH] coefficients at each level for the image as explained in Section 3.1. Figures 16, 17, and 18 show the plots of these coefficients for a chosen shared image. Figures 19, 20, and 21 show just the LL DWT

coefficients for all the levels. Figures 22, 23, and 24 show the plots of DWT coefficients for a medical image. Figures 25, 26, and 27 show just the LL DWT coefficients for all the levels.

The LL coefficients of the DWT represents the approximate image of the original image. This image carries all the required information of the image. The HL, LH, HH coefficients represent the vertical edges, horizontal edges and the diagonal edges, respectively. The coefficients other than LL are negligible and are ignored for the watermarking process. They are used during the reconstruction phase of the watermarked shared image as shown in Equations 6, 7, and 8.

The approximate image of the first level DWT becomes the input to the second level DWT, the approximate image output of the second level DWT becomes the input to the third level DWT.

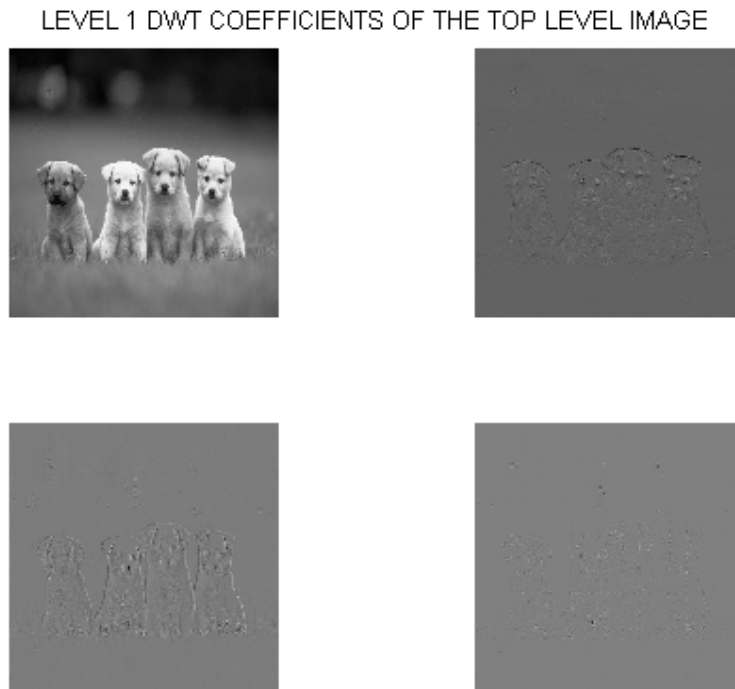

Figure 16 Level - 1 Shared Image DWT Coefficients

LEVEL 2 DWT COEFFICIENTS OF THE TOP LEVEL IMAGE

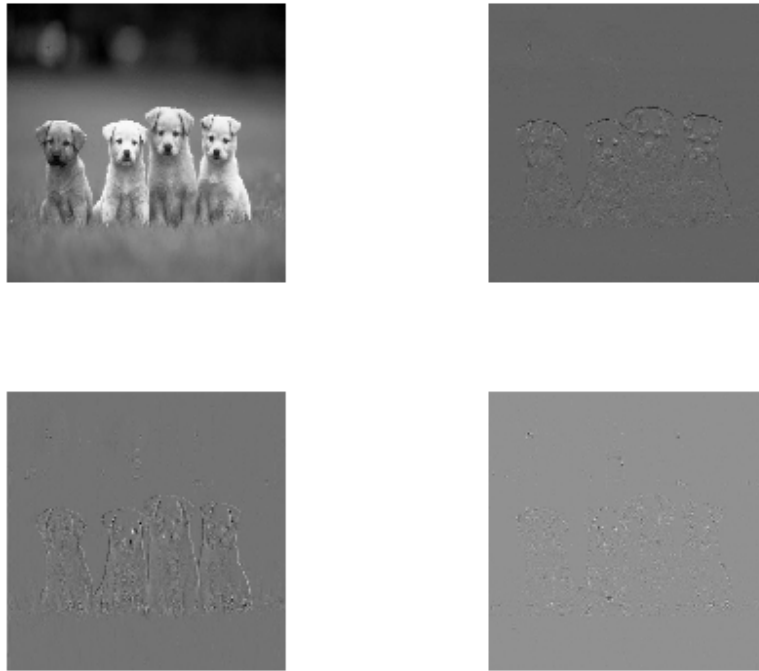

Figure 17 Level - 2 Shared Image DWT Coefficients

LEVEL 3 DWT COEFFICIENTS OF THE TOP LEVEL IMAGE

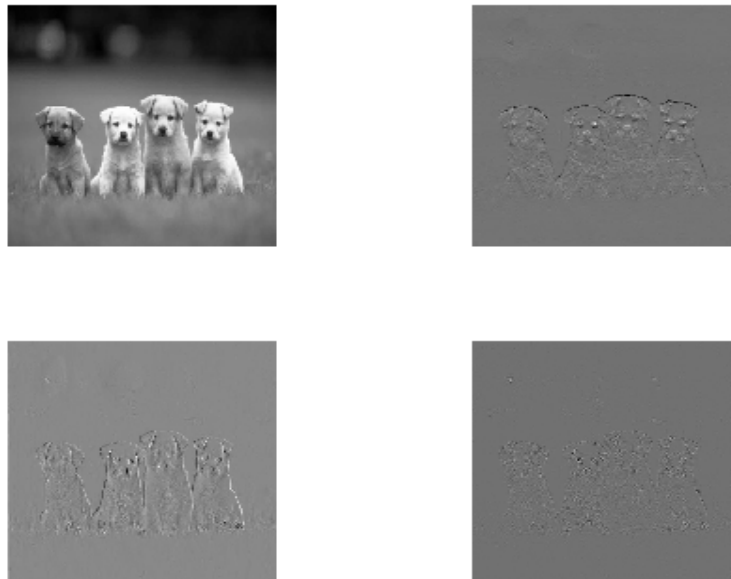

Figure 18 Level - 3 Shared Image DWT Coefficients

LEVEL 1 LL DWT COEFFICIENTS OF THE TOP LEVEL IMAGE



Figure 19 Level - 1 LL Coefficients Shared Image of Size 1024 x 1024

LEVEL 2 LL DWT COEFFICIENTS OF THE TOP LEVEL IMAGE



Figure 20 Level - 2 LL Coefficients Shared Image of Size 512 x 512

LEVEL 3 LL DWT COEFFICIENTS OF THE TOP LEVEL IMAGE



Figure 21 Level - 3 LL Coefficients Shared Image 256 x 256

LEVEL 1 DWT COEFFICIENTS OF THE MEDICAL IMAGE

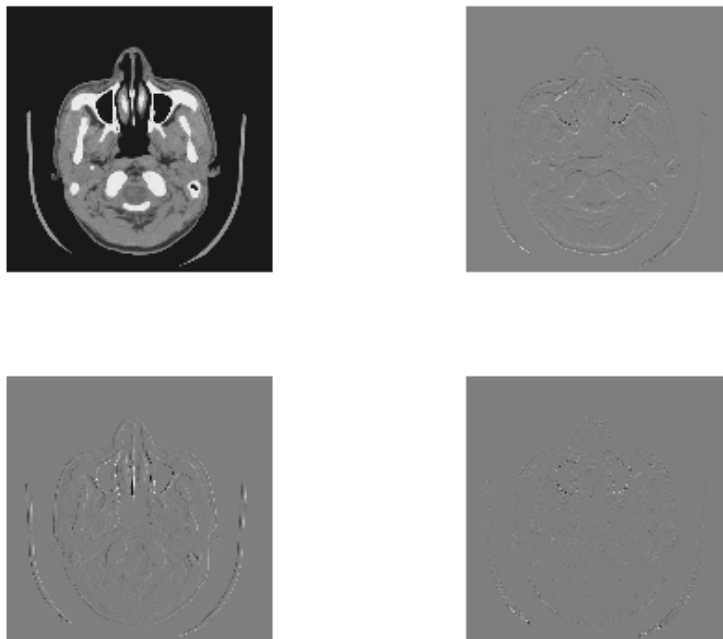

Figure 22 Level - 1 Medical Image DWT Coefficients

LEVEL 2 DWT COEFFICIENTS OF THE MEDICAL IMAGE

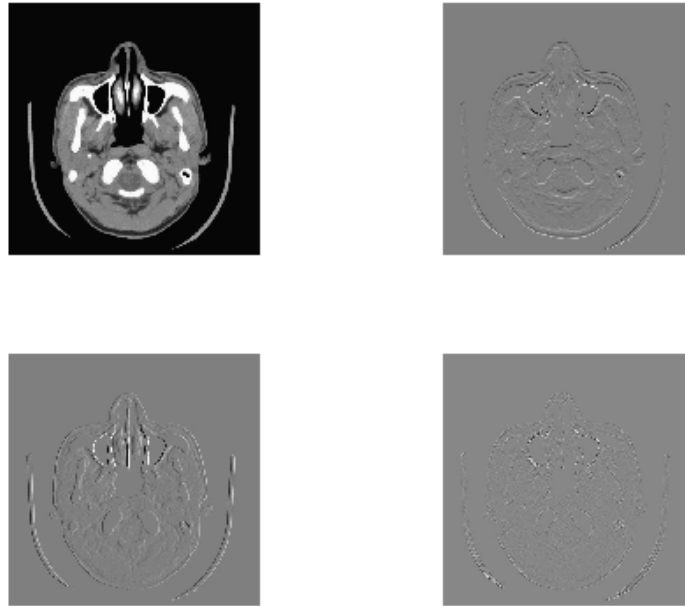

Figure 23 Level - 2 Medical Image DWT Coefficients

LEVEL 3 DWT COEFFICIENTS OF THE MEDICAL IMAGE

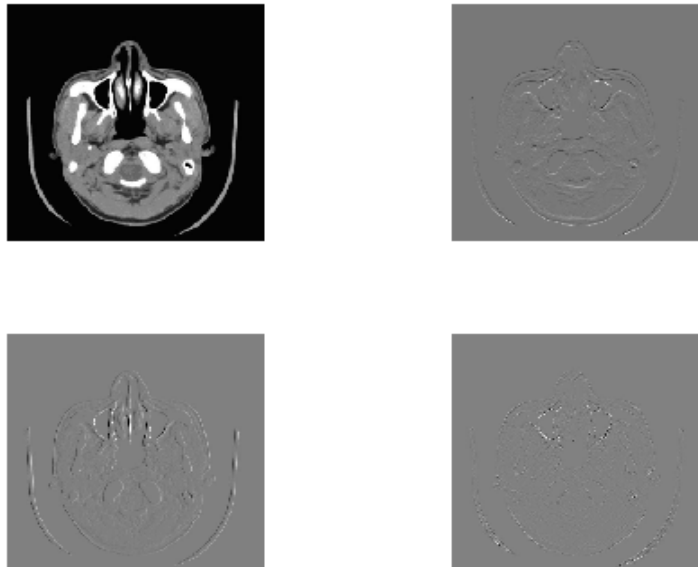

Figure 24 Level - 1 Medical Image DWT Coefficients

LEVEL 1 LL DWT COEFFICIENTS OF THE MEDICAL IMAGE

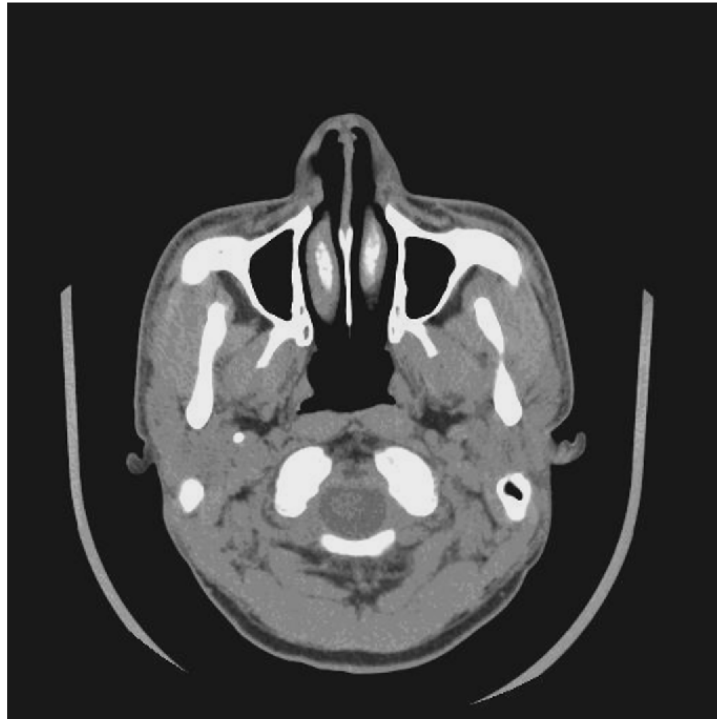

Figure 25 Level - 1 Medical LL Coefficients Image of Size 1024 x 1024

LEVEL 2 LL DWT COEFFICIENTS OF THE MEDICAL IMAGE



Figure 26 Level - 2 Medical LL Coefficients Image of Size 512 x 512

LEVEL 3 LL DWT COEFFICIENTS OF THE MEDICAL IMAGE

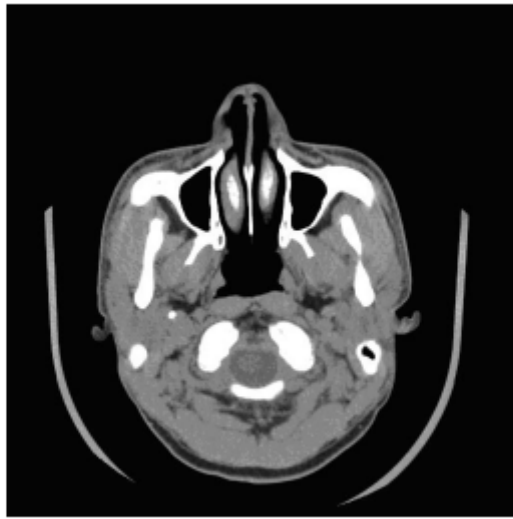

Figure 27 Level - 3 Medical LL Coefficients Image of Size 256 x 256

In the spatial domain watermarking step of the system, the level - 3 DWT coefficients of the medical image (Figure 28) is passed through a mask to find out the edges of the image. This identifies the region of non-interest (RONI) in the medical image (Figure 29). RONI can also be considered as the background of an image.

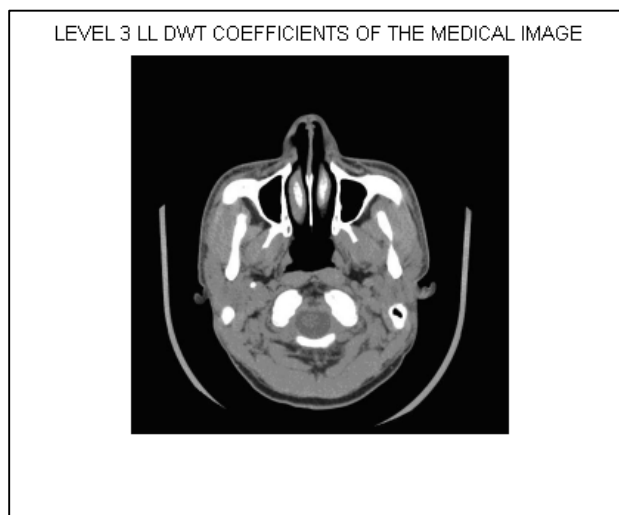

Figure 28 Medical Image for RONI

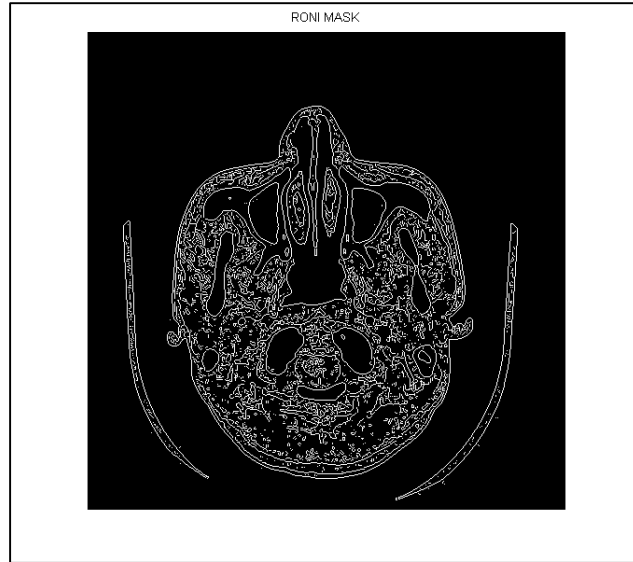

Figure 29 RONI of Medical Image

Since the entire medical image coefficients are embedded on to the shared image coefficients, the patient data shown in Figure 30 can be added to the medical image coefficients in the RONI.

The patient data image of size 128 x 128 is scrambled by a shared common key. The key generates a random sequence to randomize the pixel values of the patient data image, shown in Figure 31. Since the key used is the same at the detector end, the random sequence is built again to descramble during the detection processes. The scrambled data is complemented to change the actual pixel values from black to white.

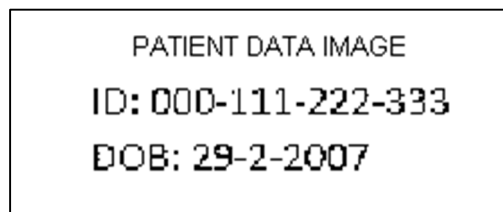

Figure 30 Patient Data Image

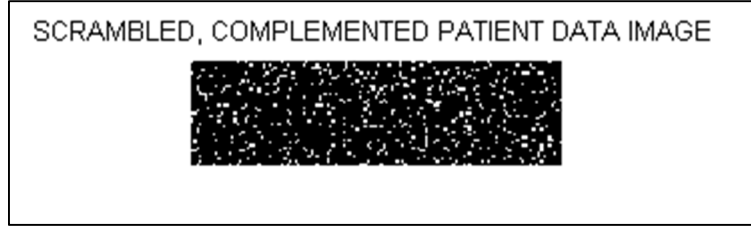

Figure 31 Scrambled Patient Data

The resultant coefficients ($LL3_m$) is multiplied by a factor (α). This product is added to the level - 3 shared image approximate coefficients ($LL3_t$) to form the new level - 3 coefficients ($LL3_{IM}$) of the shared image. The process is as in Equation (5).

$$LL3_{IM} = LL3_t + \alpha * LL3_m \quad (5)$$

The watermarked shared image is reconstructed using the same Haar wavelet filters and inverse DWT (IDWT) of the new level - 3 coefficients ($LL3_{IM}$) and level - 2 LL coefficients ($LL2$), level - 1 LL coefficients (LL) as follows:

- The new LL2 coefficients are calculated by IDWT of new level – 3 coefficients and HL3, LH3, HH3 as in Equation (6).

$$new\ LL2 = IDWT (LL3_{IM}, HL3, LH3, HH3) \quad (6)$$

- The new LL coefficients are calculated by IDWT of new level – 2 coefficients calculated in the previous step and HL2, LH2, HH2 as in Equation (7).

$$new\ LL = IDWT (new\ LL2, HL2, LH2, HH2) \quad (7)$$

- The watermarked shared image is reconstructed by IDWT of new level – 1 LL coefficients calculated in the previous step and HL, LH, HH as in Equation (8).



$$Watermarked\ Shared\ Image = IDWT (new\ LL, HL, LH, HH) \quad (8)$$

Next the quality of watermarked image is calculated using PSNR and SSIM, the SSIM calculated is the decision factor used to decide on the present alpha factor or change it to get better SSIM.

The decision rule used to select α is explained as follows. First α is set an initial value and the watermarking process is completed. The SSIM of the watermarked image is calculated. If the SSIM is below a minimum of 0.9, it means the medical data is visible on the shared image. In the next run, α is decremented by a factor $\Delta\alpha$ and the watermarking process is repeated for the new α . This process is repeated till the SSIM is at least greater than 0.9.

Table 1 lists the PSNR and SSIM values calculated for different α values and the frequency domain watermarked image. To begin with α is set to 0.4, the SSIM calculated after the water marking process is 0.24. The α factor is decremented by $\Delta\alpha = 0.2$ and the watermarking process is repeated for the new $\alpha = 0.2$. The SSIM for the new watermarked image is 0.46. In the next step, α is reduced further by $\Delta\alpha = 0.1$. The new $\alpha = 0.1$ gives the watermarked image whose SSIM = 0.97 which satisfies the decision rule. The medical image data is not perceived visibly on the final watermarked image since SSIM > 0.9. The watermarked image obtained becomes the final shared image watermarked with medical image and the patient data. Figure 32 illustrates the shared image after it is watermarked with the medical data.

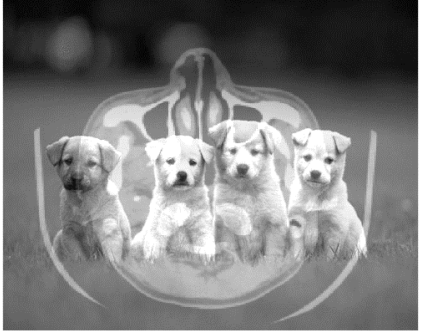
Table 1 α , PSNR and Watermarked Images

α	PSNR (dB)	SSIM	Watermarked Image
0.4	17.54	0.24	<p>TOP LEVEL IMAGE AFTER FREQUENCY DOMAIN WATERMARKING OF MEDICAL IMAGE USING DWT</p> 
0.2	23.56	0.46	<p>TOP LEVEL IMAGE AFTER FREQUENCY DOMAIN WATERMARKING OF MEDICAL IMAGE USING DWT</p> 
0.1	45.52	0.97	<p>TOP LEVEL IMAGE AFTER FREQUENCY DOMAIN WATERMARKING OF MEDICAL IMAGE USING DWT</p> 

TOP LEVEL IMAGE AFTER FREQUENCY DOMAIN WATERMARKING OF MEDICAL IMAGE USING DWT



Figure 32 Watermarked Shared Image of Size 2048 x 2048

CHAPTER 5: EXTRACTION

The extraction of the medical image and the patient data is described in this chapter. The similarity between the extracted images and the original images are measured by using SSIM and NC.

5.1 Extraction Process

The medical data extraction process is illustrated in Figure 33. The shared image is used to extract the spatial and frequency domain watermarked images.

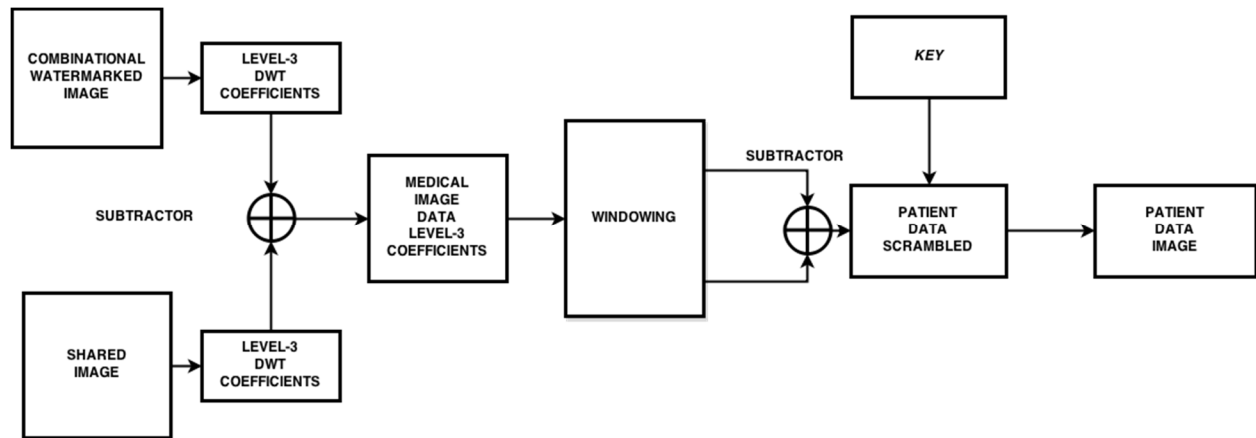

Figure 33 Extraction

The level - 3 DWT coefficients of the received watermarked image and the shared image are calculated. The difference of these coefficients is the medical image with the embedded patient data.

RECOVERED MEDICAL IMAGE

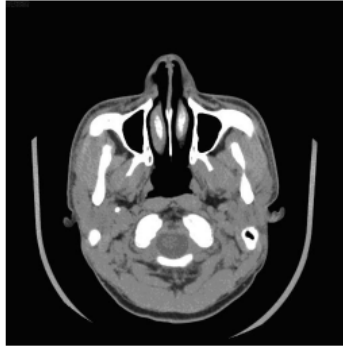

Figure 34 Recovered Medical Image

The medical data is recovered by windowing the recovered medical image data for the size of the patient data image. The background of the image is divided into smaller blocks of the size of the patient data image. The data in the blocks is descrambled using the shared key to get the patient data.

RECOVERED SCRAMBLED PATIENT DATA IMAGE



Figure 35 Recovered Scrambled Patient Data

In the next step, the patient data recovered is descrambled by generating the required sequence using the key used at the embedding stage. The descrambled patient data image is shown in Figure 36.

RECOVERED PATIENT DATA IMAGE

ID: 000-111-222-333

DOB: 29-2-2007

Figure 36 Descrambled Patient Data Image

In order to compare the recovered data with the original data SSIM and NC are used as measurement factors. As explained in Sections 3.4 and 3.5, SSIM has a range of values between '0' and '1'. SSIM of '0' means the images are completely different from each other and an SSIM of '1' means the images are exactly similar, SSIM values above 0.9 are considered to be very similar images, as good as the images rated SSIM = 1. The NC values also indicate the similarity of two images, NC = 1 means the images are exactly similar. Table 2 shows that the recovered patient data image having SSIM = 0.95 and NC = 1 and medical image having SSIM = 0.94 and NC = 1 are very similar to the images that were used at the watermarking stage (Figures 30 and 28).

Table 2 Recovered Data Measurements

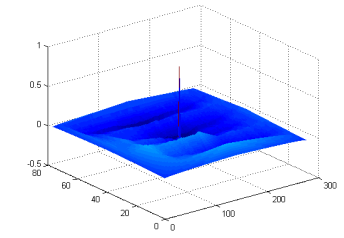
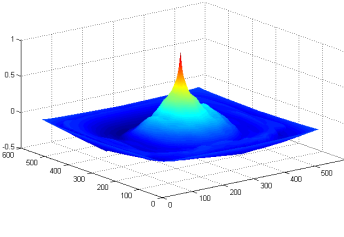
	SSIM	NC	NC PLOT
Patient Data	0.95	1	
Medical Data	0.94	1	

On addition of Gaussian noise (noise which has a probability density function equal to that of the normal distribution also known as Gaussian distribution) to the received image, the recovered images are shown in Figures 37 and 38.

ID: 000-111-222-333
DOB: 29-2-2007

Figure 37 Noise Descrambled Patient Data Image

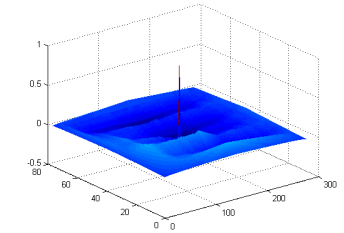
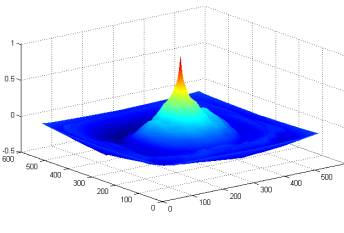

Figure 38 Noise Recovered Medical Image

The recovered images have SSIM and NC values shown in Table 3. The Gaussian noise of 4 % means, 4 % of the pixel intensity values of the total number of pixels are affected by the noise. The recovered image SSIM and NC measurements show that the proposed system has a good recovery process in presence of low intensity noise.

The recovered patient data has an SSIM = 0.75, this is due to the presence of tiny speckles on the recovered image. But the NC = 1 since the recovered image contains the original image data. SSIM = 0.923 for the recovered medical image and it has NC = 0.91, similar to the patient data, the Gaussian noise adds tiny speckles on to the medical image which reduces the SSIM.

Table 3 Recovered Data Measurements in Presence of Noise

	SSIM	NC	NC PLOT
Patient Data	0.75	1	
Medical Data	0.923	0.91	

5.1 Comparison

The results of the proposed method and the system used to compare with are tabulated in Table 4. The PSNR values obtained for the proposed system is better than one of the system considered for comparison. In an ideal scenario, the watermarked image has a PSNR value of 45.52 dB which is much greater than 39.973 dB achieved by the system in comparison. Also the extracted watermarks are similar to the original watermarks, hence the NC value is 1. When the system was checked for results in presence of Gaussian noise, the recovered medical image PSNR was 40.23 dB which is still better than the other system. But the degradation of the PSNR value from ideal case to the 4% noise addition is around 5 dB which tells us that the proposed system does not have good noise recovery if the noise levels increase.

Table 4 Comparison of Results with Existing System

	DWT and HVS model [18]		PROPOSED METHOD	
	PSNR	NC	PSNR	NC
Ideal	39.973	1	45.52	1
Gaussian Noise (4%)	36.958	0.923	40.23	0.91

CHAPTER 6: CONCLUSION

6.1 Summary

In the thesis, medical image watermarking scheme was discussed. The proposed watermarking process performs image data embedding in both frequency domain and the spatial domain. The frequency domain used is DWT.

The proposed method embeds patient data and the medical image on a shared image, the shared image can be any random image. The medical data level - 3 DWT coefficients are calculated and the approximate image obtained from the DWT coefficients is embedded with the patient data in spatial domain. The spatially watermarked DWT coefficients are embedded to the level - 3 DWT coefficients of the shared image using SSIM. The watermarked shared image is reconstructed by IDWT. In the extraction part, the patient data and the level - 3 approximate image of the medical image are recovered. The main advantages of the proposed method are:

- Uses DWT domain instead of DCT.
- Better localization in time and spatial domain.
- Better human visual system response.
- Using SSIM as an index to measure quality of watermarking instead of PSNR because SSIM accounts for human perception of image and PSNR just calculates the intensity differences between the images.

Better security of data can be achieved using the proposed system since the required data is embedded on a random image. SSIM measurements for the recovered medical image at the extraction process are greater than 0.9, which means that the perception of the images are not affected by the proposed watermarking process. This is a requirement when it comes to medical images as the diagnosis is based on the visible perception of the medical image.

One of the main disadvantages of the proposed scheme is the response to addition of noise was not satisfactory. The PSNR results obtained for the recovered images is much better than the compared system [18]. In ideal condition the recovered images had a PSNR of 45.52 dB compared to 39.973 dB by [18], in presence of 4% Gaussian noise, the recovered images had a PSNR of 40.23 dB compared to 36.958 by [18]. It was also observed that the recovered images degrade faster with the addition of noise.

6.2 Future Work

The proposed system does not have good response for addition of noise because the image degradation is more as the noise content increases. This can be eliminated by changing the watermarking process, instead of embedding the entire block of data on to the shared images. The data should be block processed by dividing the host shared image and the image data to be embedded into smaller blocks and then performing the watermarking algorithms. Also the recovered medical image is smaller in size because the recovered image is the approximate image of the level - 3 DWT coefficients, the recovered image should be resized to its original size by using image processing tools.

REFERENCES

- [1] C. Ingemar, M. Matthew, B. Jeffrey. "Digital Watermarking", Morgan Kaufmann Publishers Inc. San Francisco, CA, USA © 2008.
- [2] W. Szepanski. "A Signal Theoretic Method for Creating Forgery-proof Documents for Automatic Verification", in J. S. Jackson, editor, 1979 Carnahan Conference on Crime Countermeasures, pp. 101 - 109, 1979.
- [3] L. Holt, B. G. Maufe, and A. Wiener. "Encoded Marking of a Recording Signal", U.K. Patent GB 2196167A, 1988.
- [4] A. E. Bell. "The Dynamic Digital Disk", IEEE Spectrum, vol. 36, no. 10, pp. 28-35, 1999.
- [5] "SDMI Portable Device Specification", Part 1, Version 1.0, Document number pdwg99070802, 1999.
- [6] S. Calcote, "Developing a Secure Healthcare Information Network on the Internet," Healthcare Financial Manage, vol. 51, no. 1, pp. 68 - 76, 1997.
- [7] K. Louwse, "The Electronic Patient Record: The Management of Access— Case study: Leiden University Hospital," International Journal for Medical Information, vol. 49, no. 1, pp. 39 – 44, 1998.
- [8] H. Munch, U. Englemann, A. Schroter and H. P. Meinzer, "The Integration of Medical Images with the Patient Record and their Web Based Distribution", Journal of Academic Radiology, vol. 11, no. 6, pp. 661 – 668, 2004.
- [9] G. P. Robinson, H. D. Tagare, J. S. Duncan, and C. C. Jaffe, "Medical Image Collection Indexing: Shape- Based Retrieval using KD-trees", Computerized Medical Imaging and Graphics Journal, vol. 20, no. 4, pp. 209 – 217, 1996.
- [10] H. G. Tagare, C. C. Jaffe, and J. Duncan, "Medical Image Databases: A Content Based Retrieval Approach", Journal of American Medical Informatics Association, vol. 4, no. 3, pp. 184 – 198, 1997.
- [11] S. T. C. Wong, M. Abundo, and H. K. Huang, "Authenticity Techniques for PACS images and Records," Proceedings of SPIE, vol. 2435, pp. 68 – 79, 1995.
- [12] W. Bender, D. Gruhl, N. Morimoto, and A. Lu, "Techniques for Data Hiding", IBM Systems Journal, vol. 35, no. 3 – 4, pp. 313 – 336, 1996.

- [13] S. Kaihara, "Realization of the Computerized Patient Record: Relevance and Unsolved Problems", *International Journal on Medical Information*, vol. 49, no. 1, pp. 1 – 8, 1998.
- [14] T. H. N. Le, K.H. Nguyen, H. B. Le, " Literature Survey on Image Watermarking Tools, Watermark Attacks, and Benchmarking Tools", *Proceedings of the Second IEEE International Conferences on Advanced in Multimedia*, pp. 67 – 73, 2010.
- [15] A. Giakoumaki, S. Pavlopoulos and D. Koutsouris, "Multiple Image Watermarking Applied to Health Information Management", *IEEE Transactions on Information Technology in Biomedicine*, vol.10, no-4, pp. 722 - 732, 2006.
- [16] G. Coatrieux, H. Maitre, B. Sankur, Y. Rolland, and R. Collorec, "Relevance of Watermarking in Medical Imaging", *Proceedings of International Conference on IEEE EMBS Information Technology Applications in Biomedicine*, pp. 250 – 255, 2000.
- [17] E. T. Lin and E. J. Delp, "A Review of Fragile Image Watermarks", *Proceedings of ACM Multimedia Security Workshop*, pp. 47 – 51, 1999.
- [18] L. Zhang, X. Yan, H. Li, and M. Chen, "A Dynamic Multiple Watermarking Algorithm based on DWT and HVS", *International Journal on Communications, Network and System Sciences*, pp. 490 - 495, 2012.
- [19] F. Y. Shih, S. Y. T. Wu, "Combinational Image Watermarking in the Spatial and Frequency Domains", *Pattern Recognition Society*, pp. 969-975, 2002.
- [20] S. Mallat, "A Theory for Multiresolution Signal Decomposition: The Wavelet Representation", *IEEE Pattern Analysis and Machine Intelligence*, vol. 11, no. 7, pp. 674 - 693, 1989.
- [21] P. Christine, W. J. Zeng, "Image Adaptive Watermarking using Visual Models", *IEEE Journal on Selected Areas in Communications*, vol. 16, no. 4, pp. 525 - 539, 1998.
- [22] W. Zhou, Bovik, C. Alan, "Image Quality Assessment from Error Visibility Similarity", *IEEE Transactions on Image Processing*, vol. 13, no. 4. pp. 600 - 612, 2004.
- [23] J. P. Lewis, "Fast Normalized Cross-Correlation", *Vision Interface*, pp. 120 - 123, 1995.
- [24] I. J. Cox, J. Killian, T. Leighton, and T. Shamoan, "Secure Spectrum Watermarking for Images Audio and Video", *IEEE International Conference on Image Processing*, vol. 3, pp. 243 - 246, 1996.
- [25] Q. Liu and J. Ying, "Grayscale Image Digital Watermarking Technology based on Wavelet Analysis", *IEEE Symposium on Electrical & Electronics Engineering*, pp. 618 - 621, 2012.

APPENDICES

Appendix A Copyright Permissions

Below is permission for the use of Figure 12.

3/29/2015 RightsLink® by Copyright Clearance Center

Copyright Clearance Center RightsLink® Home Create Account Help Live Chat

 Requesting permission to reuse content from an IEEE publication

Title: Image quality assessment: from error visibility to structural similarity
Author: Zhou Wang; Bovik, A.C.; Sheikh, H.R.; Simoncelli, E.P.
Publication: Image Processing, IEEE Transactions on
Publisher: IEEE
Date: April 2004
Copyright © 2004, IEEE

LOG IN
If you're a copyright.com user, you can login to RightsLink using your copyright.com credentials. Already a RightsLink user or want to learn more?

Thesis / Dissertation Reuse

The IEEE does not require individuals working on a thesis to obtain a formal reuse license, however, you may print out this statement to be used as a permission grant:

Requirements to be followed when using any portion (e.g., figure, graph, table, or textual material) of an IEEE copyrighted paper in a thesis:

- 1) In the case of textual material (e.g., using short quotes or referring to the work within these papers) users must give full credit to the original source (author, paper, publication) followed by the IEEE copyright line © 2011 IEEE.
- 2) In the case of illustrations or tabular material, we require that the copyright line © [Year of original publication] IEEE appear prominently with each reprinted figure and/or table.
- 3) If a substantial portion of the original paper is to be used, and if you are not the senior author, also obtain the senior author's approval.

Requirements to be followed when using an entire IEEE copyrighted paper in a thesis:

- 1) The following IEEE copyright/ credit notice should be placed prominently in the references: © [year of original publication] IEEE. Reprinted, with permission, from [author names, paper title, IEEE publication title, and month/year of publication]
- 2) Only the accepted version of an IEEE copyrighted paper can be used when posting the paper or your thesis on-line.
- 3) In placing the thesis on the author's university website, please display the following message in a prominent place on the website: In reference to IEEE copyrighted material which is used with permission in this thesis, the IEEE does not endorse any of [university/educational entity's name goes here]'s products or services. Internal or personal use of this material is permitted. If interested in reprinting/republishing IEEE copyrighted material for advertising or promotional purposes or for creating new collective works for resale or redistribution, please go to http://www.ieee.org/publications_standards/publications/rights/rights_link.html to learn how to obtain a License from RightsLink.

If applicable, University Microfilms and/or ProQuest Library, or the Archives of Canada may supply single copies of the dissertation.

BACK **CLOSE WINDOW**

Copyright © 2015 Copyright Clearance Center, Inc. All Rights Reserved. [Privacy statement](#). [Terms and Conditions](#).
Comments? We would like to hear from you. E-mail us at customerservice@copyright.com

<https://www.copyright.com/AppDispatchServlet?fromTop> 1/1